

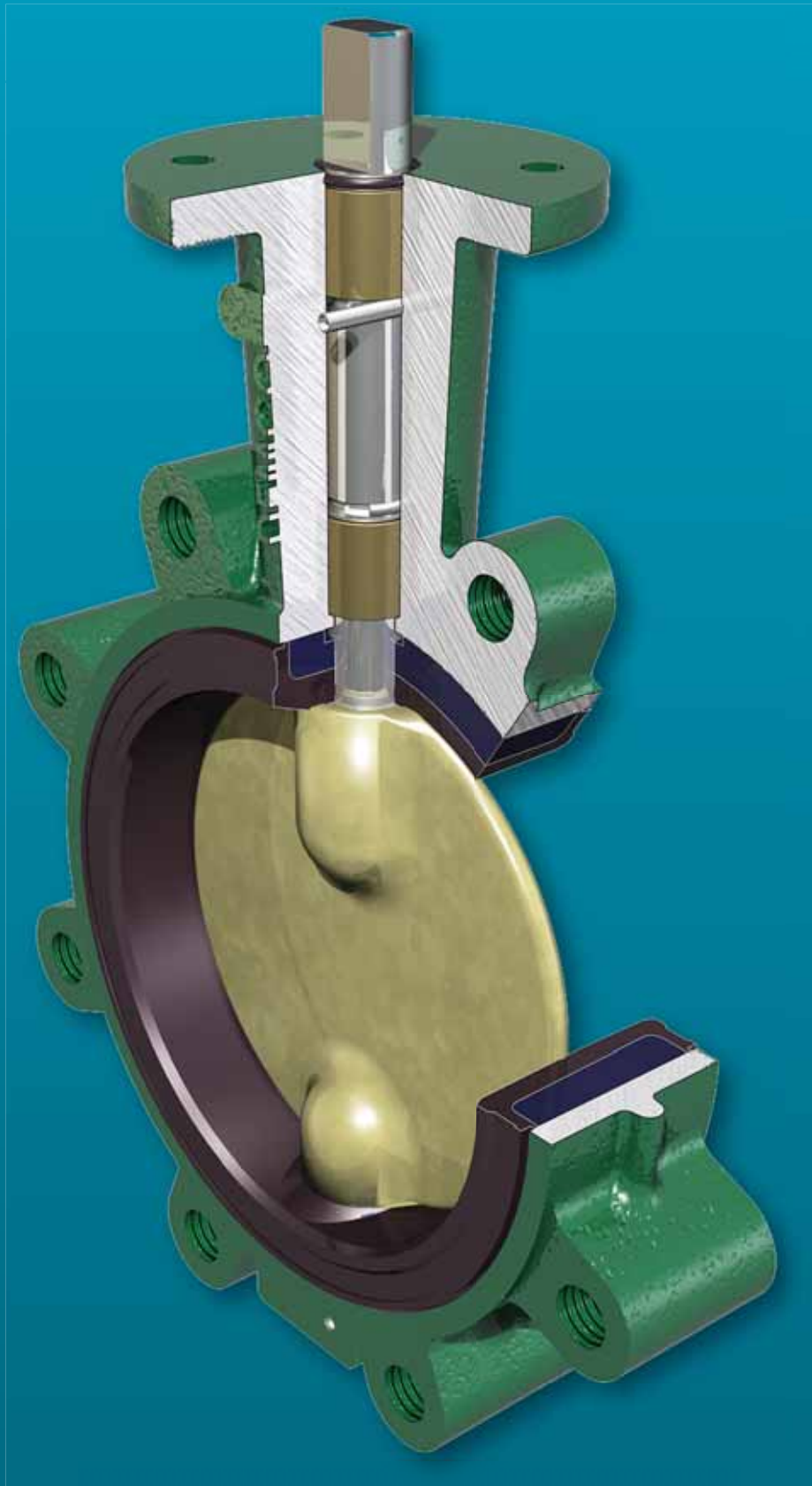

Butterfly-Style DEMCO Valves

Quality design and rugged dependability for rigorous industrial, oilfield, and drilling applications



Contents

Introduction	4
Features and benefits	5
Styles and accessories	8
Base part numbers and weights	13
Marine series	14
Component parts list	15
Dimensional data (valves)	17
Handles	22
Worm gear operators	23
General technical information	25
Torque data	26
Standard material data	26
Fire test	27



Oklahoma City, Oklahoma, USA

Introduction

Cameron is a leading provider of valves, valve automation, and measurement systems to the oil and gas industry. Our products are primarily used to control, direct, and measure the flow of oil and gas as it is moved to refineries, petrochemical plants, and industrial centers for processing.

We provide valve products that are sold through distributor networks worldwide. Our products are used in oil and gas and industrial applications and include widely recognized brands such as DEMCO* valves; NAVCO* floating ball valves; NEWCO* gate, globe, and check valves; DOUGLAS CHERO* forged-steel gate, globe, and check valves; NUTRON* ball valves; TOM WHEATLEY* check valves; WHEATLEY* check valves; and WKM* valves.

Designed for dependable, heavy-duty performance in abrasive and corrosive service conditions, butterfly-style DEMCO valves are commonly selected for a number of oilfield applications, including drilling and production.

Features and Benefits

As one of the most durable resilient-seated butterfly valves in the industry, the Cameron butterfly-style DEMCO valve excels in a variety of applications.

Cast in both wafer and tapped lug patterns in a variety of material choices, butterfly-style DEMCO valves feature a one-piece body for reduced weight and increased strength.

The unique stem hole design in the disc ensures a dry stem journal. The hard-backed seat enables ease of installation, reliable operation, and infield repairability without special tools. Butterfly-style DEMCO valves are available in sizes 2 to 36 in [50 to 900 mm].

Engineered for long-term, reduced-maintenance performance, butterfly-style DEMCO valves are commonly selected for a variety of applications in the following industries:

- chemical and petrochemical
- agriculture
- oil and gas drilling and production
- food and beverage
- water and wastewater
- cooling towers (HVAC)
- power
- mining and materials
- dry bulk handling
- marine and government.

Bidirectional sealing

The butterfly-style DEMCO valve provides bidirectional sealing at full-rated pressure with identical flow from either direction.

Integral flange seal

An integral flange seal molded into the edge of the seat accommodates ASME weld neck, slip-on, threaded, socket, and stub-end type C flanges.

ASME Class 150 rating

With a body rating of American Society of Mechanical Engineers (ASME) Class 150 (285-psi nonshock), the wafer body diameters are designed to self-center in the ASME Class 150 flange pattern.

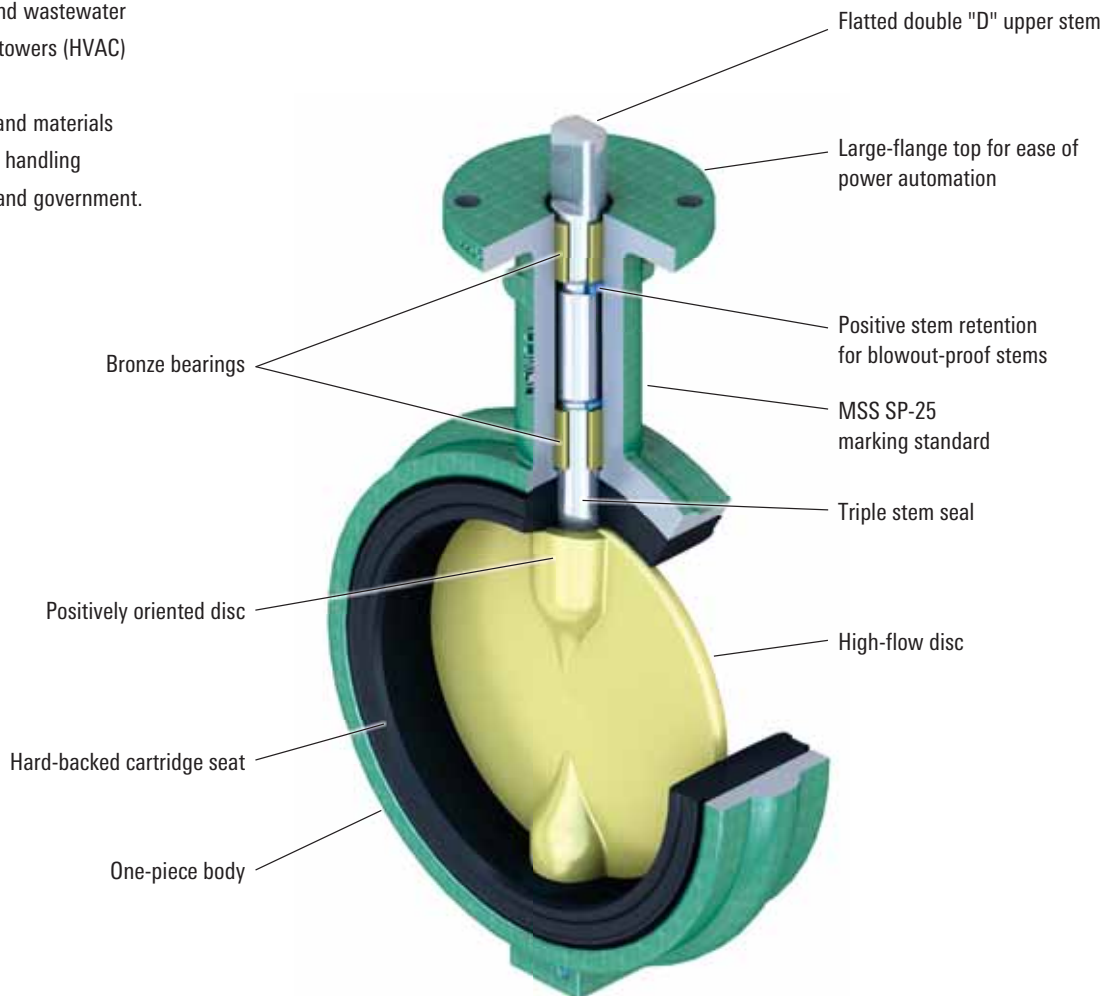

Wafer-style DEMCO valve.

Features and Benefits

Multiple pressure ratings

Three drop-tight pressure ratings are offered for 2- to 12-in [50- to 300-mm] sizes. The standard shutoff pressure rating is 200 psi, but 285- and 50-psi shutoff ratings are also available. A throttling 0-psi-rated valve is available where drop-tight closure is not required and minimal torque is desired. Both the 50-psi and throttling ratings allow for smaller actuators, which can significantly reduce overall installation cost in automated applications. The 14- to 36-in [350- to 900-mm] valves are available in 150- and 285-psi drop-tight shutoff ratings.

Dry stem journal that reduces potential for leakage

The DEMCO valve's disc is uniquely designed with a continuous annular-raised band around the stem hole and disc edge, which presses flat into the seat at every angular position.

The resilient seat presses back with a higher force than the line pressure, preventing leakage to the stem. In addition, two O-ring ribs are provided in the seat stem bore, creating a triple stem seal. In comparing stem seal designs with boot seats, a seal is accomplished by an interference squeezing on the stem or an O-ring in the stem journal. The potential for leakage behind the seat is high for this type of design. As the disc wipes the seat, elongation of the stem seal area enables leakage to collect behind the seat. This condition is reduced by the DEMCO valve's dry stem journal and hard-backed seat.

Hard-backed cartridge seat

The DEMCO valve's cartridge seat is constructed by permanently bonding a resilient elastomer to a rigid backing ring. In addition to superior sealing integrity, this design

- makes valve installation easier because no special precautions are required for disc position, which is especially advantageous when installing valves with fail-closed actuators
- reduces high torque and premature failure caused by elastomer distortion, as found in other nonrigid seat designs
- simplifies seat replacement because the seat is slip-fitted into the body with no need for special tools.

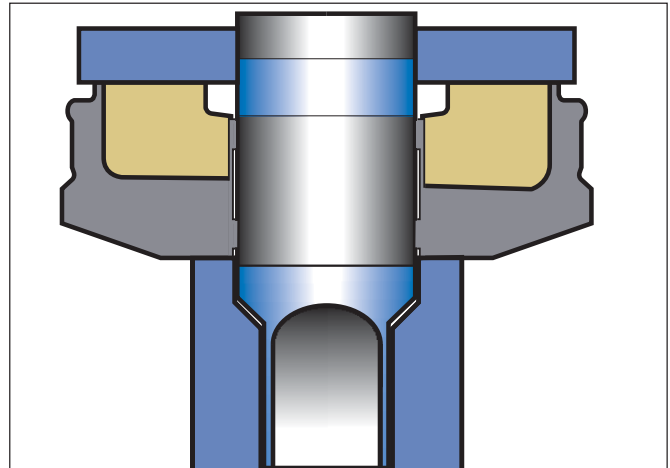

Dry stem journal.

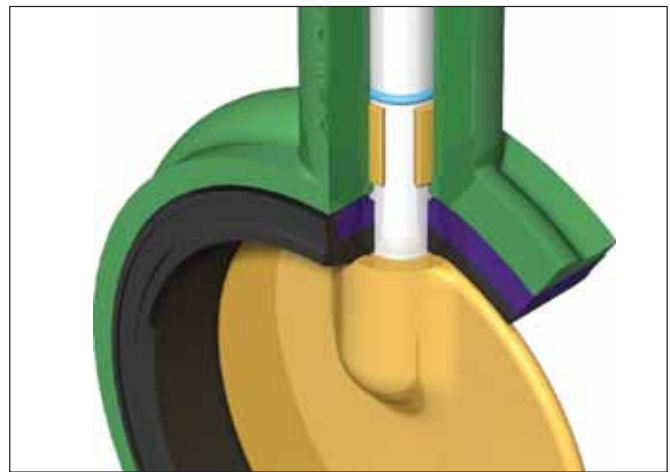

Hard-backed cartridge seat.

Positively oriented disc

The rectangular drive ensures the proper orientation of the stem disc connection. In 2- to 24-in [50- to 600-mm] size valves, the disc is permitted to float on the stem to center in the valve seat. This design enhances drop-tight sealing and prolongs service life.

End-of-line service

Lug body valves may be used in end-of-line service with downstream piping removed. Only weld-neck or socket flanges can be used for this service. Since upstream pressure is excluded between the flange and the seat face by the DEMCO valve's flange seal design, there is no effective force to slide the seat downstream. The 2- to 12-in [50- to 300-mm] lug butterfly-style DEMCO valves are suitable for liquid service up to 200 psi with downstream piping removed at 150 psi for 14- to 36-in [350- to 900-mm] valves.

Lug body valves are recommended for isolation of pumps, control devices, or other system components, which may need to be removed for repair or replacement. Lug valves also are suitable for installation at points from which piping expansion may proceed. Such valves normally are blanked with blind flanges to protect the exposed seats until new piping is attached.

Design and testing specifications

- MSS SP-67 (testing is applicable upon request)
- MSS SP-25 (standard marking system for valves)

In addition, butterfly-style DEMCO valves can be supplied to comply with these standards:

- ABS
- CE/PED
- CRN
- DNV
- EAC
- API Spec 607 4th Ed. fire test
- US Coast Guard 46 CFR 56.20.

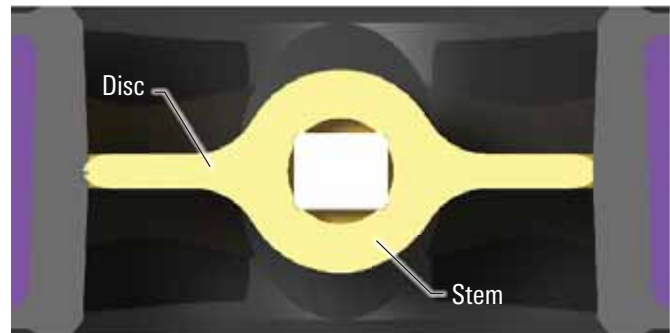

Positively oriented disc.

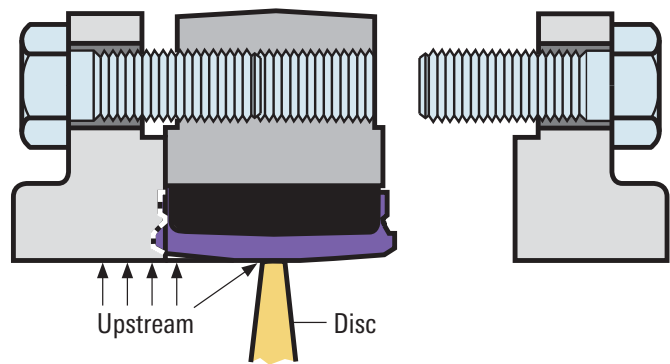

End-of-line service.

Specifications

Specifications			
Sizes, in [mm]		2 to 36 in [50 to 900 mm]	
Body type and style designations	Long-neck NE-C and NF-C	2- to 36-in [50- to 900-mm] wafer or lug	
	Short-neck NE-I	2- to 12-in [50- to 300-mm] wafer or lug	
	NE-D and NE-D SP	2- to 12-in [50- to 300-mm] wafer	
	Marine	2- to 36-in [50- to 900-mm] wafer or lug	
Standard pressure rating, psi		Standard	Options
	2 to 12 in [50 to 300 mm]	200	0 (throttling), 50, and 285
	14 to 36 in [350 to 900 mm]	150	285
Operating temperatures, degF [degC]	-30 to 300 [-34 to 149], depending on seat material selection and application (see page 26)		
Standard material options		Standard	Options
	Bodies	Ductile iron	Aluminum bronze, carbon steel, and SS
	Discs	Nickel-plated ductile iron, aluminum bronze, and stainless steel (SS)	ZPEX® coated ductile iron (see note)
	Stems	416 SS	316 SS
	Seats	Buna-N, FKM	Ethylene propylene diene monomer (EPDM) and natural rubber

Note: Many more options available (consult Cameron or see pages 10, 11 and 12 on how to order).
 Fire-safe API Spec 607 4th Edition, CRN, ABS, DNV, EAC, and PED certifications on selected sizes and pressure rating.

Styles and Accessories

Butterfly-style DEMCO valves come in a variety of styles to suit a range of applications. In addition, a variety of quality accessories are available to further enhance its suitability to the application.

Series NE-C

Sizes 2 to 12 in [50 to 300 mm] are available in both wafer and lug styles. This series is a general-purpose valve with a neck length designed to provide full clearance for the valve top over 2 in of insulation on ASME Class 150 pipe flanges.

Series NE-I

Sizes 2 to 12 in [50 to 300 mm] are suited for a range of applications in many industries, including food and beverage, utilities, and process flowlines. This short neck design is offered in a variety of body materials. The valves are designed for installation between ASME Class 125 and 150 flanges.

Series NE-D

The valves in this series can be made in sizes 2 to 12 in [50 to 300 mm]. The Series NE-D valve is a short-neck valve with body notches to fit popular, lightweight flange patterns, making it ideal for both the bulk material handling and the transportation industries. Valves also will center in ASME Class 125 and 150 flanges.

The valves are designed for installation between ASME Class 125 and 150 flanges. The Series NE-D valve is also available with the short-pattern version (**NE-D SP**).

Series NF-C

Sizes 14 to 36 in [350 to 900 mm] are available in both wafer and lug styles. The wafer body has two drilled locator lugs at the top and bottom for ASME Class 150 flanges. Bronze bearings are installed on both stems for reduced operating torque.



*Series NF-C lug 16 in [400 mm].
Also available in wafer style (not shown).*



Series NE-C lug 6 in [150 mm].

Series NE-C wafer 6 in [150 mm].



Series NE-I lug 8 in [200 mm].

Series NE-I wafer 3 in [80 mm].



Series NE-D wafer 4 in [100 mm].

Marine

Butterfly-style DEMCO valves for marine applications are available in the NE-C lug, NE-I lug and wafer, NE-D wafer, and NF-C lug styles and conform to

- Title 46 of the Code of Federal Regulations
- Part 56 of the US Coast Guard's Marine Engineering Regulations
- US Coast Guard Category (A) Acceptance on API Spec 607 qualified valves
- American Bureau of Shipping Standard, including tagging per MSS SP-25 and testing per MSS SP-67.

Actuators

Consult Cameron or visit cameron.slb.com/valves for actuation options.

Handles and stem extensions

There are three basic handle designs that are compatible with any 2- to 12-in [50- to 300-mm] valve: ten-position locking, two-position locking, and memory stop. Memory-stop handles provide throttling, which is infinitely adjustable and can be set by a lock nut with a memory-stop setting (adjustable open stop). Handles are available in basic trim, corrosion-resistant trim, and sanitary trim. Please consult Cameron for information on stem extension.

Gear operators

DEMCO valve weatherproof gear operators are offered with a choice of handwheel. The worm gear has either self-locking set screws to control open and closed positioning or an optional adjustable memory-stop for balance return to a preset open position after closing.



DEMCO valve with actuator.



DYNATORQUE valve accessories gear box.*

Styles and Accessories

Series NE-C, NE-I, NE-D(SP)

2 to 12 in [50 to 300 mm]

Key No.	Quantity	Description	Material
1	One	Body	See How to Order for material choices and styles
2	One	Seat	
3	One	Disc	
4	One	Upper stem	
6	One	Lower stem	
7	Two	Spring pin	SS
14	One	Retainer	SS
22	One	Top O-ring	Buna-N
23	Two required for fire-safe valves	Stem O-ring	Buna-N
24	2	Bearing	Bronze

Complete material specifications on page 26.

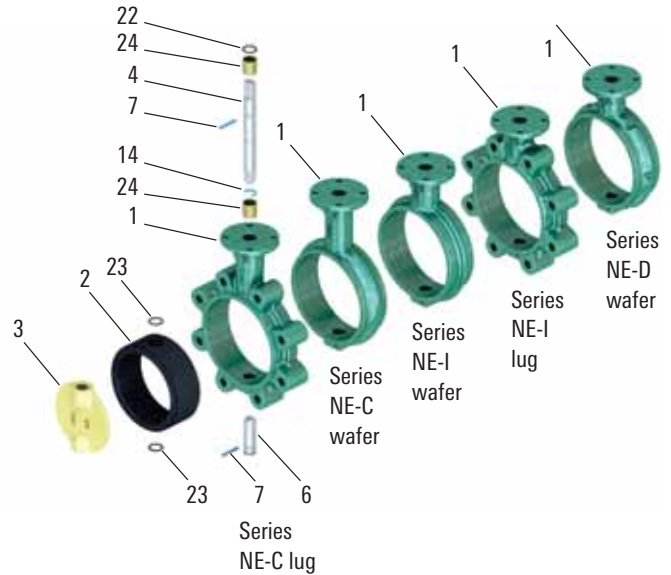

How to Order

XX	XXXXX	X	X	X	X	XX	X
Fire safety	Base part number	Body configuration	Body material [†]	Stem material	Disc material	Seat elastomer	Action
Non-fire safe	J0	NE-C, NE-I	NE-C (long neck)	NE-C, NE-I, and NE-D	NE-C, NE-I, and NE-D	NE-C, NE-I, and NE-D	Handle
		Wafer 1	Ductile iron (lug) 1	316 SS 2	Buna-N 31	Ten-position locking 1	
		Lug 5	Ductile iron (wafer) 2	Aluminum bronze 4	FKM 34	Bare stem 9	
		NE-D	NE-I^{**}	Optional ^{††}	Optional ^{††}	Optional ^{††}	Optional ^{††}
		Wafer 1	Ductile iron (NE-I, wafer only) 1	Ductile iron, nickel-plated 5	Peroxide-cured EPDM 35	Two-position locking 6	
			Optional	Optional ^{††}	Natural rubber 36	Ten-position locking; corrosion resistant K	
			Aluminum bronze 3	ZPEX [®] coated ductile iron A		Gear operators[§]	
			Carbon steel (NE-I only) 4			Handwheel A	
			SS 8			Bare shaft E	
			NE-D				
			Ductile iron 1				

Based on valve series and shutoff pressure. See page 13.

[†] Standard coating is green enamel; other coatings are available on request.

[†] 17-4 PH[®] SS for 8- to 12-in [200- to 300-mm] upper stem only.

[§] Gear operator recommended for 8- to 12-in [200- to 300-mm] sizes in all series.

^{††} Please consult Cameron for legacy material.

(Example: 6-in [150-mm] NE-C, 200-psi, wafer, standard trim with handle—22124-1215311)

Series NF-C

14 to 24 in (350 to 600 mm)

Key No.	Quantity	Description	Material
1	1	Body	See How to Order for material choices and styles
2	1	Seat	
3	1	Disc	
4	1	Upper stem	
6	1	Lower stem	
7	2	Spring pin	SS
14	1	Retainer (spacer) [†]	SS
22	1	Top O-ring	Buna-N
23	Two required for fire-safe valves	Stem O-ring	Buna-N
24	2	Bearing	Bronze

Complete material specifications are on page 26.

[†]14- to 20-in [350- to 500-mm] spacer.

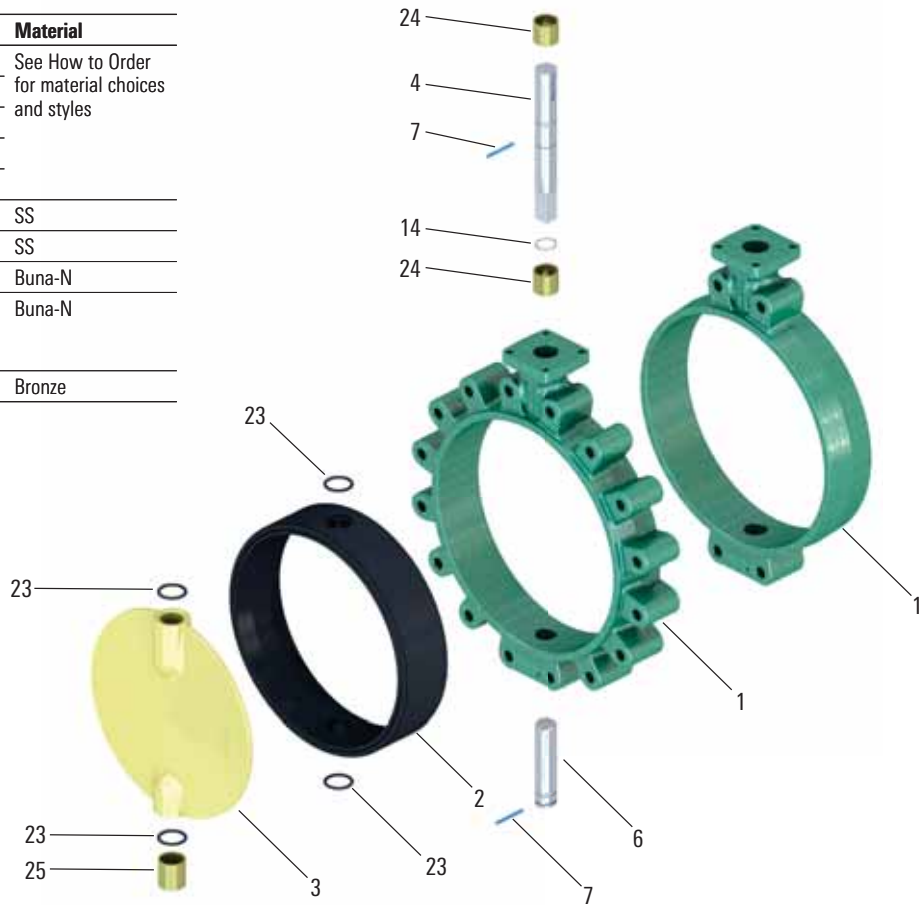

How to Order

XX	XXXXX	X	X	X	X	XX	X
Fire safety	Base part number	Body configuration	Body material [†]	Stem material	Disc material	Seat elastomer	Actuation [‡]
Non-fire safe	J0	Wafer 1	Ductile iron (lug) 1	416 SS 1	316 SS 2	Buna-N 31	None 9
		Lug 5	Ductile iron (wafer) 2	Optional [†]	Aluminum bronze 4	FKM 34	Gear operators
			Optional	316 SS 2	Nickel-plated ductile iron 5	Optional [†]	Handwheel A
			Aluminum bronze (lug) 3		Optional [†]	EPDM 35	Bare shaft E
			Steel (lug) 4		ZPEX coated ductile iron A		
			SS (lug) 8				

Based on valve series and shutoff pressure. See page 13.

[†]Standard coating is green enamel; other coatings are available on request.

[‡]Please consult Cameron for legacy material.

(Example: 18-in [450-mm] NF-C, 150-psi lug, SS trim, Buna-N seat, WGO—23822-512231A)

Styles and Accessories

Series NF-C

30 and 36 in [750 and 900 mm]

30-in [750-mm] NF-C BOM

Key No.	Quantity	Description	Material
1	One	Body	See How to Order for material choices and styles.
2	One	Seat—hard backed	
3	One	Disc	
4	One	Upper stem	
6	One	Lower stem	
7	Two	Disc screw	18-8 SS
8	One	Key-ring	SS
9	Two required for fire-size valves	O-ring	Buna-N
14	One	Spacer	Steel
24	Two	Upper bearing	Bronze
25	One	Lower bearing	Bronze
26	One	Thrust collar	Bronze
27	One	Set screw	18-8 SS
28	One	Cap	Ductile iron
29	Four	Screw	Carbon steel
30	Four	Lock washer	Carbon steel

Complete material specifications on page 26.

36-in [900-mm] NF-C BOM

Key No.	Quantity	Description	Material
1	One	Body	See How to Order for material choices and styles.
2	One	Seat—hard backed	
3	One	Disc	
4	One	Upper stem	
6	One	Lower stem	
8	One	Key	SS
10	Two required for fire-size valves	O-ring	FKM
11	One	O-ring	Buna-N
23	One	Upper bearing	DU® bearing
24	One	Upper bearing	DU bearing
25	Two	Lower bearing	DU bearing
27	One	Set screw	18-8 SS
29	Eight	Screw	Carbon steel
30	Eight	Lock washer	Carbon steel

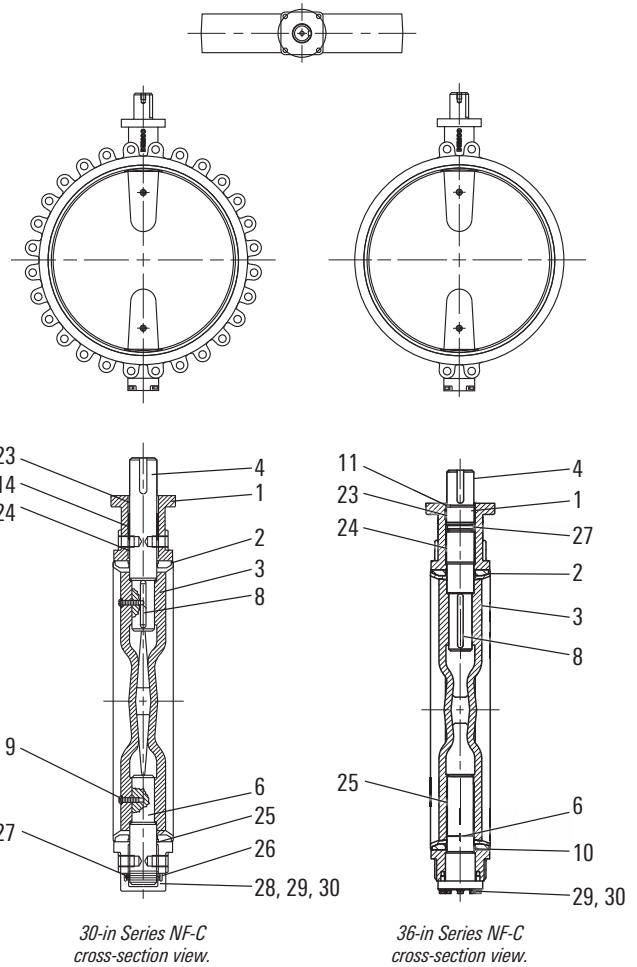

How to Order

XX	XXXXX	X	X	X	X	XX	X
Fire safety	Base part number	Body configuration	Body material [†]	Stem material	Disc material	Seat elastomer	Actuation [‡]
Non-fire safe J0	Wafer 1 Lug 5	Ductile iron (wafer or lug) 1	416 SS 1 Optional [†] 316 SS 2	316 SS 2 Aluminum bronze 4 Nickel-plated ductile iron 5 Optional [†] ZPEX coated ductile iron A	Buna-N 31 FKM 34 Optional [†] EPDM 35	Bare stem 9 Gear operators Handwheel A Bare shaft E	

Based on valve series and shutoff pressure. See page 13.

[†]Standard coating is green enamel; other coatings are available on request.

[‡]Please consult Cameron for legacy material.

(Example: 36 in [900 mm], 150 psi, bronze disc, EPDM seat with gear operator—24357-111435A)

Base Part Numbers and Weights

Series NE-C*

Description, in [mm]	2 [50]	2½ [65]	3 [80]	4 [100]	5 [125]	6 [150]	8 [200]	10 [250]	12 [300]	
200 psi	22119	22120	22121	22122	22123	22124	22125	22126	22127	
285 psi	22225	22226	22227	22228	22229	22230	22231	22232	22233	
Throttling	22243	22244	22245	22246	22247	22248	22249	22250	22251	
Weight, lbm/bare stem	Wafer	5.8	7.0	7.7	11.4	14.7	17.6	28.5	47.9	71.0
	Lug	8.0	9.9	10.7	17.0	24.5	28.5	43.5	65.9	98.5

Series NE-I†

Description, in [mm]	2 [50]	2½ [65]	3 [80]	4 [100]	5 [125]	6 [150]	8 [200]	10 [250]	12 [300]	
200 psi	22128	22129	22130	22131	22132	22133	22134	22135	22136	
285 psi	22252	22253	22254	22255	22256	22257	22258	22259	22260	
Throttling	22270	22271	22272	22273	22274	22275	22276	22277	22278	
Wafer weight, lbm/bare stem	Iron, steel, SS	4.9	6.4	6.9	10.2	13.7	16.4	28.4	44.8	66.8
	Bronze	4.7	6.2	6.7	9.9	13.4	16.0	28.0	44.3	66.3
	Aluminum	2.8	3.4	4.1	5.9	8.7	10.8	18.2	30.4	47.2
Lug weight, lbm/bare stem	Bronze	6.8	8.7	9.5	15.7	23.1	27.0	42.0	64.4	96.8
	Steel, SS	7.0	8.9	9.7	16.0	23.5	27.5	42.5	64.9	97.5

Series NE-D†

Description, in [mm]	2 [50]	2½ [65]	3 [80]	4 [100]	5 [125]	6 [150]	8 [200]	10 [250]	12 [300]
200 psi	22181	22129	25093	22183	22184	22185	22134	22186	22136
285 psi	22279	22253	25135	22281	22282	22283	22258	22284	22260
200-psi Series NE-D SP square stem	2326563	–	2326564	2326497	2326565	2326566	2326569	2326567	232656
Throttling	22291	22271	25136	22293	22294	22295	22276	22296	22278
Wafer weight, lbm/bare stem	4.9	6.4	6.9	10.2	13.7	16.4	28.4	44.8	66.8

*Gear operator recommended for 8 to 12 in [200 to 300 mm] sizes.

Series NF-C

Description, in [mm]	14 [350]	16 [400]	18 [450]	20 [500]	24 [600]	30 [750]	36 [900]	
150 psi	23820	23821	23822	23823	23824	24141	24357	
285 psi	25318	25319	25320	25321	25322	25323	25324	
Weight, lbm/bare stem	Wafer	102	166	214	257	401	935	1,500
	Lug	116	203	239	332	535	1,050	2,020

Marine valves: consult Cameron for B-255, B-256, and B-258 data sheets.

Marine Series

Butterfly-style DEMCO valves for marine applications meet all the requirements of US Coast Guard's Marine Engineering Regulations as outlined in Title 46 of the Code of Federal Regulations, Part 56 and the American Bureau of Shipping Standard, including tagging per MSS SP-25 and testing per MSS SP-67. All valves are shell tested at 1½ times rated working pressure and seat tested at rated working pressure.

Marine Series										
Description	in [mm]	2 [50]	2½ [65]	3 [80]	4 [100]	5 [125]	6 [150]	8 [200]	10 [250]	12 [300]
200 psi		22923	22924	22925	22926	22927	22928	22929	22930	22931
285 psi		22914	22915	22916	22917	22918	22919	22920	22921	22922
Weight, lbm/bare stem, NE-C long-neck body										
Wafer	Ductile iron	5.8	7.0	7.7	11.4	14.7	17.6	28.5	47.9	71.0
Lug	Ductile iron	8.0	9.9	10.7	17.0	24.5	28.5	43.5	65.9	98.5
NE-I short-neck body										
Wafer	Iron, steel, SS	4.9	6.4	6.9	10.2	13.7	16.4	28.4	44.8	66.8
	Bronze	4.7	6.2	6.7	9.9	13.4	16.0	28.0	44.3	66.3
Lug	Bronze	6.8	8.7	9.5	15.7	23.1	27.0	42.0	64.4	96.8
	SS, steel	7.0	8.9	9.7	16.0	23.5	27.5	42.5	64.9	97.5
Description	in [mm]	14 [350]	16 [400]	18 [450]	20 [500]	24 [600]	30 [750]	36 [900]		
150 psi		24611	24612	24613	24614	24615	2227182	2227183		
285 psi		25302	25303	25304	25305	25306	25307	25308		
Weight, lbm/bare stem, NF-C long-neck body										
Lug	Ductile iron	116	203	239	332	535	1,050	2,020		
	Bronze	113	199	235	325	525	N/A	N/A		

How to Order

XX	XXXXX	X	X	X	X	XX	X	XX
Fire safety	Base part number	Body configuration	Body material ¹	Stem material ²	Disc material ²	Seat elastomer ²	Actuation	Certification
Non-fire safe	J0	Wafer 1	Ductile iron 1	416 SS 1	SS 2	Buna-N ¹ 31	Ten-position handle 1	ABS 01
Fire safe ³	F0	Lug 5	Optional	Optional	Aluminum bronze ¹ 4	FKM 34	Two-position locking 6	DNV 02
			Aluminum bronze 3	316 SS 2	Optional	EPDM ¹ 35	Worm gear handwheel A	PED 03
			Carbon steel 4		ZPEX coated ductile iron 5	Natural rubber 36		CRN 04
			SS 8					

Base part number of valve shown above.

¹ Standard base trim options.

² Please consult Cameron for legacy material.

³ See page 27 for information on fire-safe design.

Note: 30 and 36 in [750 and 900 mm] only available with ductile iron lug body.

(Example: 6-in [150-mm] 200-psi wafer, standard trim with ten-position handle—22928-1114311)

Component Parts List

Series NE-C, NE-I, NE-D

Consult Cameron for replacement parts for Series NE, NE-S, and NE-N.

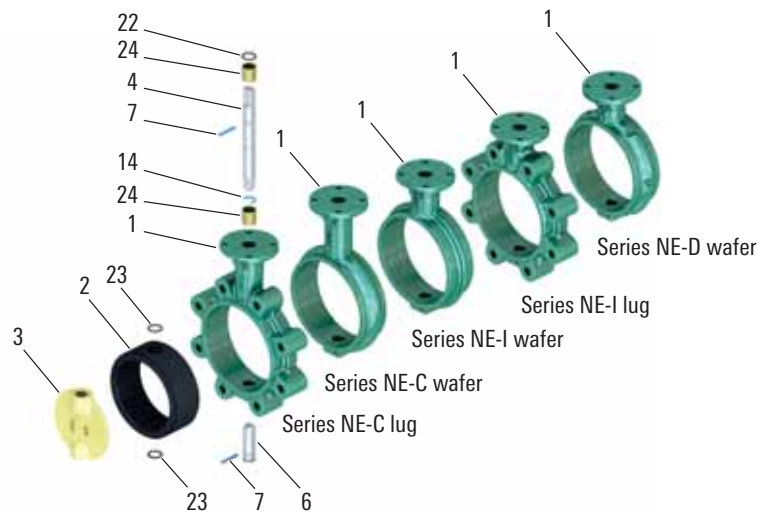

Key	Description	2 in [50 mm]	2½ in [65 mm]	3 in [80 mm]	4 in [100 mm]	5 in [125 mm]	6 in [150 mm]	8 in [200 mm]	10 in [250 mm]	12 in [300 mm]		
1	Body	NE-C wafer options	22137-011	22138-011	22139-011	22140-011	22141-011	22142-011	22143-011	22144-011	22145-011	
			ASTM A395 ductile iron -011									
		NE-C lug options	21986-051	21987-051	21988-051	21989-051	21990-051	21991-051	21992-051	21993-051	21994-051	
		NE-I wafer options	ASTM A395 ductile iron -051									
			22681-01X	22682-01X	22683-01X	22684-01X	22685-01X	22686-01X	22687-01X	22688-01X	22689-01X	
			ASTM A395 ductile iron -011; ASTM B148 aluminum bronze -013; ASTM A216 WCB steel -014; ASTM A351 SS -018									
	NE-I lug options	22695-05X	22696-05X	22697-05X	22698-05X	22699-05X	22700-05X	22701-05X	22702-05X	22703-05X		
	NE-D wafer options	ASTM B148 aluminum bronze -053; ASTM A216 WCB steel -054; ASTM A351 SS -058										
		22187-021	22682-011	20594-021	22189-021	22190-021	22191-021	22687-011	22192-021	22689-011		
		ASTM A395 ductile iron -0X1										
2	Seat	1786-XXX	1788-XXX	1790-XXX ⁵⁵	1792-XXX	1794-XXX	1002-XXX	1798-XXX	1815-XXX	1817-XXX		
	Options	Buna-N -031; FKM -034; EPDM [†] -135; natural rubber -036										
3	Disc	200 psi	22045-0XX	22046-0XX	22047-0XX	22048-0XX	22049-0XX	22050-0XX	22051-0XX	22052-0XX	22053-0XX	
		285 psi	22196-0XX	22197-0XX	22198-0XX	22199-0XX	22200-0XX	22201-0XX	22202-0XX	22203-0XX	22204-0XX	
		Throttling	22214-0XX	22215-0XX	22216-0XX	22217-0XX	22218-0XX	22219-0XX	22220-0XX	22221-0XX	22222-0XX	
		Options	316 SS -002; nickel-plated ductile iron -005; aluminum bronze [‡] -014; ZPEX ductile iron									
4	Upper stem	NE-C	22066-00X	22067-00X	22067-00X	22068-00X	22069-00X	22069-00X	22070-00X	22071-00X	22072-00X	
		NE-I	22073-00X	22074-00X	22074-00X	22075-00X	22076-00X	22076-00X	22077-00X	22078-00X	22079-00X	
		NE-D	22073-00X	22074-00X	22193-00X	22194-00X	22195-00X	22195-00X	22077-00X	22078-00X	22079-00X	
	Upper stem	NE-C	22334-00X	22335-00X	22335-00X	22336-00X	22337-00X	22337-00X	22338-00X	22339-00X	22340-00X	
	Utility top	NE-I	22341-00X	22342-00X	22342-00X	22343-00X	22344-00X	22344-00X	22345-00X	22346-00X	22347-00X	
6	Lower stem	22080-00X	22081-00X	22081-00X	22082-00X	22083-00X	22083-00X	22084-00X	22085-00X	22086-00X		
	Stem material options	416 SS -001; 316 SS [§] -002										
7	Spring pin (two)	302 SS	5448-18720	5448-18720	5448-18720	5448-18720	5448-18724	5448-18724	5448-25028	5448-25028	5448-25028	
14	Retainer	SS	22117	22117	22117	13704	13705	13705	13705	13706	13707	
22	Top O-ring	Buna-N	5526-114	5526-114	5526-114	5526-115	5526-117	5526-117	5526-117	5526-119	5526-125	
23	Stem O-ring ^{††}	Buna-N	5526-113	5526-115	5526-115	5526-116	5526-212	5526-212	5526-212	5526-214	5526-220	
24	Bearing (two)	Bronze	22526-001	22118-001	22118-001	13112-001	13115-001	13115-001	13115-001	13116-001	13117-001	

[†] EPDM seat options: standard — peroxide cured: -135.

[‡] 8 to 12 in [200 to 300 mm], 285-psi aluminum bronze, use -024.

[§] 8 to 12 in [200 to 300 mm], upper stem 17-4 PH SS (part number suffix -012), lower stem 316 SS.

^{††} Four required for throttling (0-psi) valves only.

⁵⁵ 3-in [80 mm] NE-D seat part number 25095-XXX.

Component Parts List

Series NF-C

Consult Cameron for replacement parts for series NF.

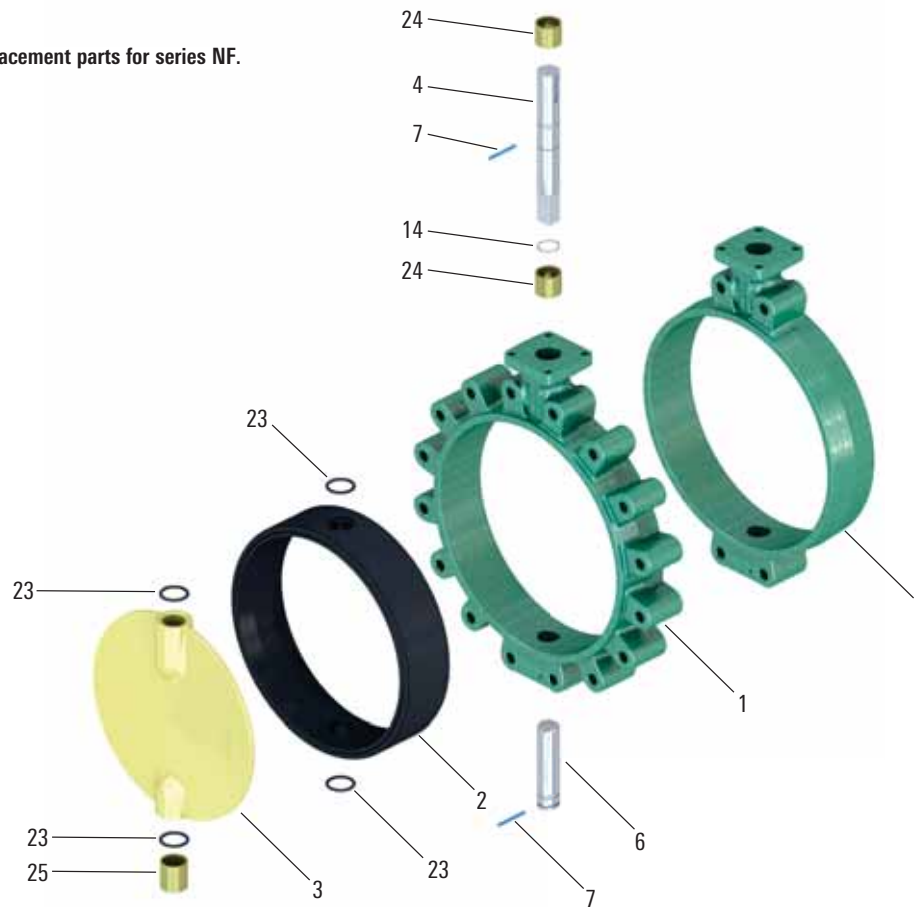

Key	Quantity	Description		14 [350]	16 [400]	18 [450]	20 [500]	24 [600]	Material
1	1	Body	Lug	23827-051	23911-051	23901-051	23891-051	23875-051	Ductile iron (lug) -051
			Wafer	23825-011	23907-011	23899-011	23881-011	23873-011	Ductile iron (wafer) -012
2	1	Seat							Buna-N -031
				23829-03X	23913-03X	23903-03X	23893-03X	7103-03X	FKM -034
									EPDM [§] -X35
3	1	Disc	150 psi	23830-0XX	23915-0XX	23905-0XX	23895-0XX	23877-0XX	316 SS -002
			285 psi	25309-0XX	25310-0XX	25311-0XX	25312-0XX	25313-0XX	Aluminum bronze -014
									Nickel-plated iron -005
			PVF coated	24460-001	24461-001	24462-001	24463-001	24464-001	
4	1	Upper stem		23833-00X	23917-00X	23897-00X	23897-00X	23879-00X	416 SS -001, 316 SS -002
6	1	Lower stem		23834-00X	23918-00X	23898-00X	23898-00X	23880-00X	
7	2	Spring pin		5446-25040	5446-25040	5446-25048	5446-25048	5446-25064	SS
14	1	Retainer (spacer) [†]		5502-137	5502-150	5502-175	5502-175	24470	Steel
23	– [†]	Disc O-ring		5526-220	5526-223	5526-328	5526-328	5526-331	Buna-N
24	2	Upper bearing		5086-044	5086-050	5086-048	5086-048	5086-046	Bronze
25	1	Lower bearing		5086-045	5086-051	5086-049	5086-049	5086-047	Bronze

[†]Four required for throttling valves only.

[†]14- to 20-in [350- to 500-mm] retainer, 24-in [600-mm] spacer.

[§]EPDM seat options: standard — peroxide cured: -135.

Dimensional Data (Valves)

Series NE-C

2 to 12 in [50 to 300 mm]

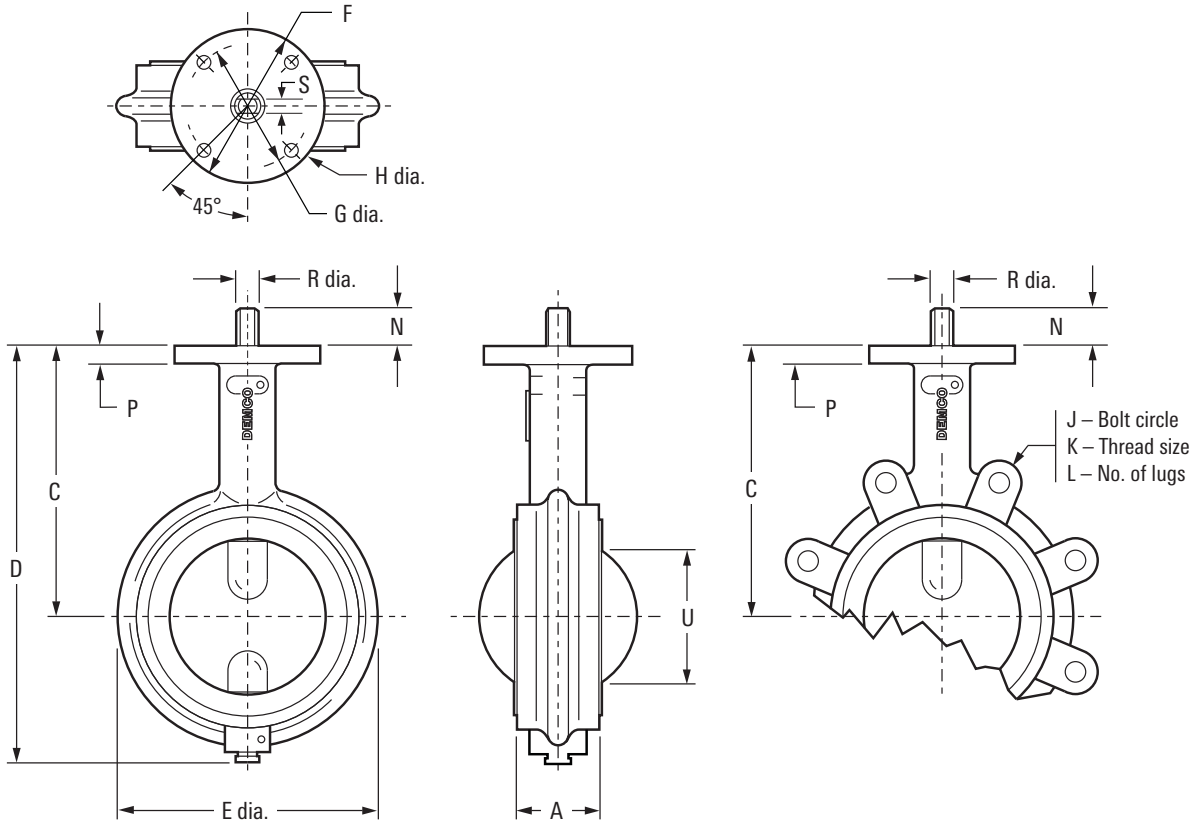

Size, in	A	C	D	E	F	G	H	J	K	L	N	P	R	S	U
2	1.74	5.62	8.44	4.12	4.00	3.25	0.408	4.75	5/8-11	4	1.00	0.44	0.625	0.375	1.467
2½	1.86	6.12	9.19	4.88	4.00	3.25	0.408	5.50	5/8-11	4	1.00	0.44	0.625	0.375	2.144
3	1.86	6.38	9.69	5.38	4.00	3.25	0.408	6.00	5/8-11	4	1.00	0.44	0.625	0.375	2.743
4	2.11	7.12	11.00	6.88	4.00	3.25	0.408	7.50	5/8-11	8	1.00	0.44	0.625	0.375	3.601
5	2.24	7.75	12.12	7.75	4.00	3.25	0.408	8.50	3/4-10	8	1.25	0.44	0.838	0.500	4.582
6	2.24	8.25	13.25	8.75	4.00	3.25	0.408	9.50	3/4-10	8	1.25	0.44	0.838	0.500	5.624
8	2.54	9.44	15.56	11.00	6.00	5.00	0.533	11.75	3/4-10	8	1.38	0.56	0.838	0.500	7.429
10	2.74	11.25	18.69	13.38	6.00	5.00	0.533	14.25	7/8-9	12	1.38	0.56	0.963	0.625	9.382
12	3.24	12.19	21.69	16.12	6.00	5.00	0.533	17.00	7/8-9	12	1.38	0.56	1.338	0.750	11.35
Size, mm															
50	44	143	214	105	102	83	10.36	121	5/8-11	4	25	11.2	15.88	9.53	37
65	47	155	233	124	102	83	10.36	140	5/8-11	4	25	11.2	15.88	9.53	54
80	47	162	246	137	102	83	10.36	152	5/8-11	4	25	11.2	15.88	9.53	70
100	54	181	279	175	102	83	10.36	191	5/8-11	8	25	11.2	15.88	9.53	91
125	57	197	308	197	102	83	10.36	216	3/4-10	8	32	11.2	21.29	12.70	116
150	57	210	337	222	102	83	10.36	241	3/4-10	8	32	11.2	21.29	12.70	142.8
200	65	240	395	279	152	127	13.54	298	3/4-10	8	35	14.2	21.29	12.70	189
250	70	286	475	340	152	127	13.54	362	7/8-9	12	35	14.2	24.46	15.88	238
300	82	310	551	409	152	127	13.54	432	7/8-9	12	35	14.2	33.99	19.05	288

Note: 2- to 12-in [50- to 300-mm] disc will open into Sch. 80 pipe ID.

Dimensional Data (Valves)

Series NF-C

14 to 24 in [350 to 600 mm]

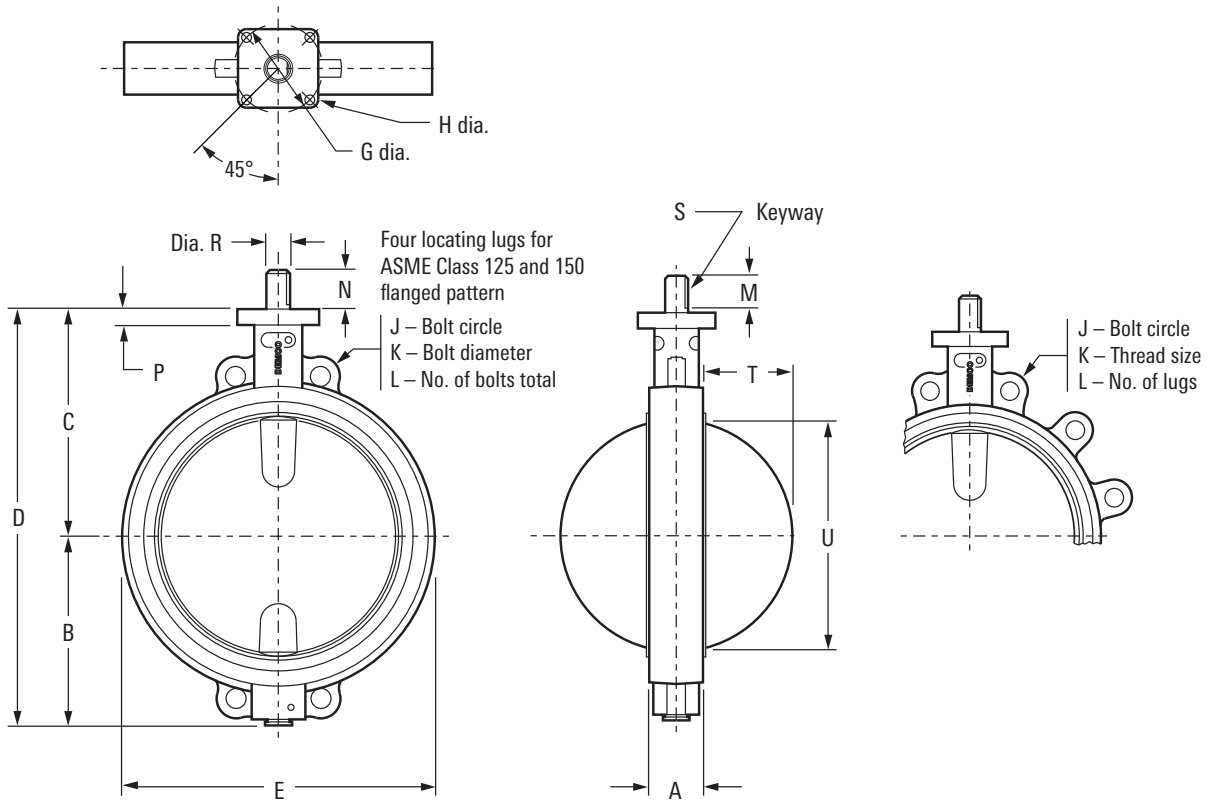

Size, in	A	B	C	D	E	G	H	J	K	L	M	N	P	R	S	T	U
14	3.00	10.63	12.75	23.4	16.20 17.3 [†]	5.00	0.56	18.75	1-8 1 [†]	12	2.00	2.25	0.88	1.375	5/16 × 5/32	5.12	12.89
16	4.00	11.66	13.75	25.4	18.16 19.2 [†]	5.00	0.56	21.25	1-8 1 [†]	16	2.00	2.25	0.88	1.625	3/8 × 3/16	5.65	14.76
18	4.50	12.96	14.75	27.7	20.35 21.4 [†]	6.50	0.81	22.75	1 1/8-7 1 1/8 [†]	16	2.50	2.75	1.00	1.875	1/2 × 3/16	6.37	16.63
20	5.00	13.97	15.75	29.7	22.63 23.6 [†]	6.50	0.81	25.00	1 1/8-7 1 1/8 [†]	20	2.50	2.75	1.00	1.875	1/2 × 3/16	7.12	18.58
24	6.00	16.19	19.00	35.2	27.31 28.3 [†]	6.50	0.81	29.50	1 1/4-7 1 1/4 [†]	20	2.50	3.00	1.00	1.875	1/2 × 3/16	8.67	22.56
Size, mm																	
350	76	270	324	594	411 439 [†]	127	14.2	476	1-8 1 [†]	12	51	57	22.4	34.93	7.94 × 3.97	130	327
400	102	296	349	645	461 488 [†]	127	14.2	540	1-8 1 [†]	16	51	57	22.4	41.28	9.53 × 4.76	144	375
450	114	329	375	704	517 544 [†]	165	20.6	578	1 1/8-7 1 1/8 [†]	16	64	57	25.4	47.63	12.70 × 4.76	162	422
500	127	355	400	754	575 599 [†]	165	20.6	635	1 1/8-7 1 1/8 [†]	20	64	57	25.4	47.63	12.70 × 4.76	181	472
600	152	411	483	894	694 719 [†]	165	20.6	749	1 1/4-7 1 1/4 [†]	20	64	76	25.4	47.63	12.70 × 4.76	220	573

[†]Wafer valve dimension is the bottom figure. Lug valve dimension is the top figure.

Series NF-C

30 to 36 in [750 to 900 mm]

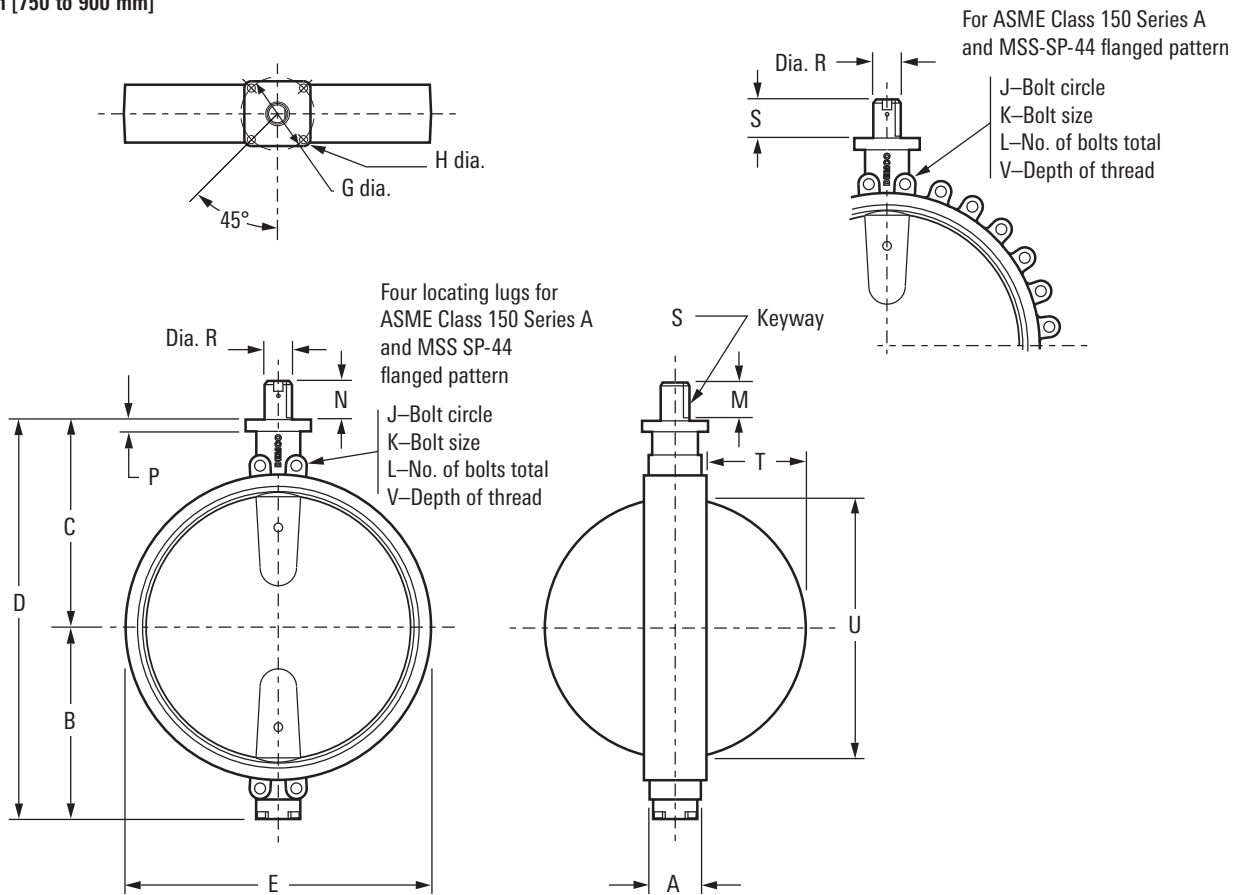

Size, in	A	B	C	D	E	G	H	J	K	L	M	N	P	R	S	T	U	V	W
30	6.50	21.2	23.0	44.2	34.1	8.00	0.69	36.00	1¼-7UNC	28	3.4	3.7	1.2	3.000	¾ × ⅜	11.45	28.55	1.750	28.67
36	7.88	25.0	27.8	52.8	40.5	10.25	0.81	42.75	1½-6UNC	32	4.0	4.4	1.5	3.625	⅞ × ⅞	13.86	34.71	1.750	34.70
Size, mm																			
750	165	538	584	1,123	866	203	17.53	914	1¼-7UNC	28	86	94	30.5	76.2	19.05 × 9.53	291	725	44.45	728
900	200	635	706	1,342	1,029	260	20.57	1,086	1½-6UNC	32	102	112	38.1	92.1	22.23 × 11.11	352	882	44.45	881

Dimensional Data (Valves)

Series NE-D(SP)

2 to 12 in [50 to 300 mm]

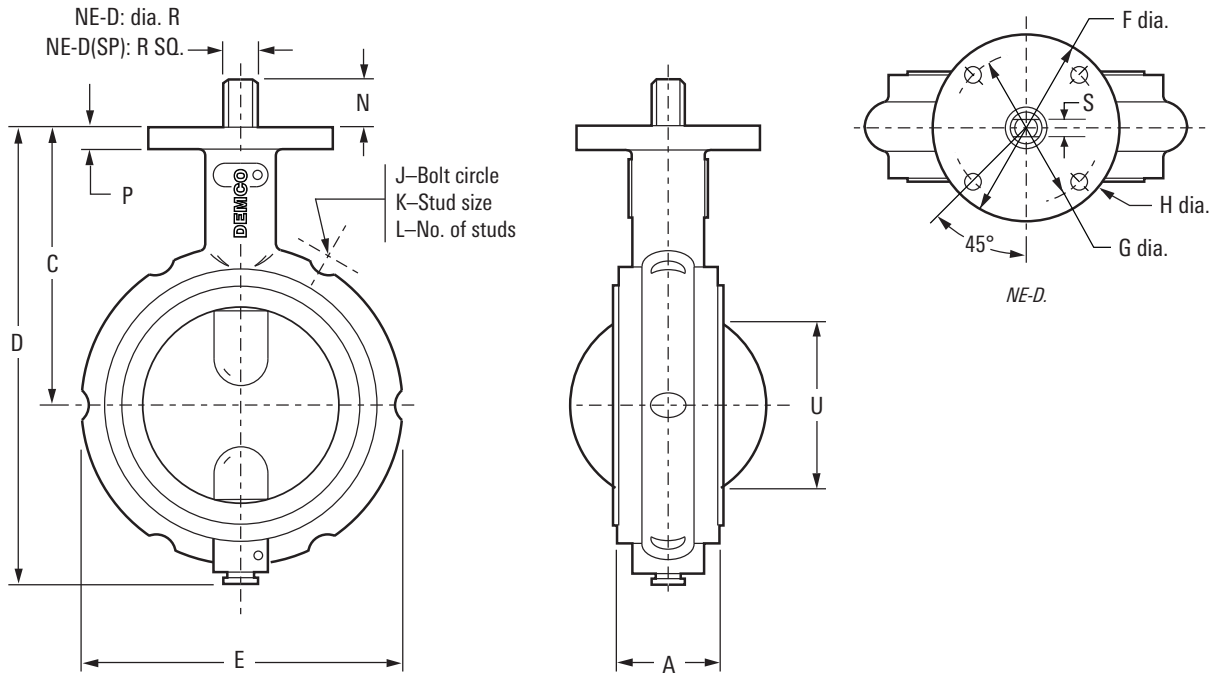

Size, in	A		C	D	E	F	G	H	J	K	L	N	P	R		S	U
	NE-D	NE-D(SP)												NE-D	NE-D(SP)		
2	1.74	1.62	3.94	6.75	4.12	4.00	3.25	0.408	4.27	3/8	4	1.00	0.44	0.625	0.624	0.375	1.467
2½	1.86	—	4.44	7.50	4.88	4.00	3.25	0.408	5.31	3/8	4	1.00	0.44	0.625	—	0.375	2.144
3	1.86	1.75	4.88	8.19	5.38	4.00	3.25	0.408	4.91	3/8	6	1.00	0.44	0.625	0.624	0.375	2.743
4	2.11	2.00	6.00	9.88	6.88	4.00	3.25	0.408	7.03	1/2	6	1.00	0.44	0.625	0.624	0.375	3.601
5	2.24	2.12	6.00	10.38	7.75	4.00	3.25	0.408	7.56	1/2	6	1.25	0.44	0.838	0.624	0.500	4.582
6	2.24	2.12	6.50	11.50	8.75	4.00	3.25	0.408	9.16	1/2	8	1.25	0.44	0.838	0.624	0.500	5.624
8	2.54	2.54	8.06	14.19	11.00	6.00	5.00	0.533	11.72	5/8	8	1.38	0.56	0.838	0.874	0.500	7.428
10	2.74	2.50	9.97	17.41	13.38	6.00	5.00	0.533	13.72	5/8	8	1.38	0.56	0.963	0.874	0.625	9.382
12	3.24	3.00	10.91	20.41	16.12	6.00	5.00	0.533	16.62	1/2	12	1.38	0.56	1.338	1.124	0.750	11.35
Size, mm																	
50	44	41.15	100	171	105	102	83	10.36	108	10	4	25	11.2	15.88	15.85	9.53	37
65	47	—	113	191	124	102	83	10.36	135	10	4	25	11.2	15.88	—	9.53	54
80	47	44.45	124	208	137	102	83	10.36	125	10	6	25	11.2	15.88	15.85	9.53	70
100	54	50.80	152	251	175	102	83	10.36	179	15	6	25	11.2	15.88	15.85	9.53	91
125	57	53.85	152	264	197	102	83	10.36	192	15	6	32	11.2	21.29	15.85	12.70	116
150	57	53.85	165	292	222	102	83	10.36	233	15	8	32	11.2	21.29	15.85	12.70	142.8
200	65	64.52	205	360	279	152	127	13.54	298	16	8	35	14.2	21.29	22.20	12.70	189
250	70	63.50	253	442	340	152	127	13.54	348	16	8	35	14.2	24.46	22.20	15.88	238
300	82	76.20	277	518	409	152	127	13.54	422	15	12	35	14.2	33.99	28.55	19.05	288

Series NE-I

2 to 12 in [50 to 300 mm]

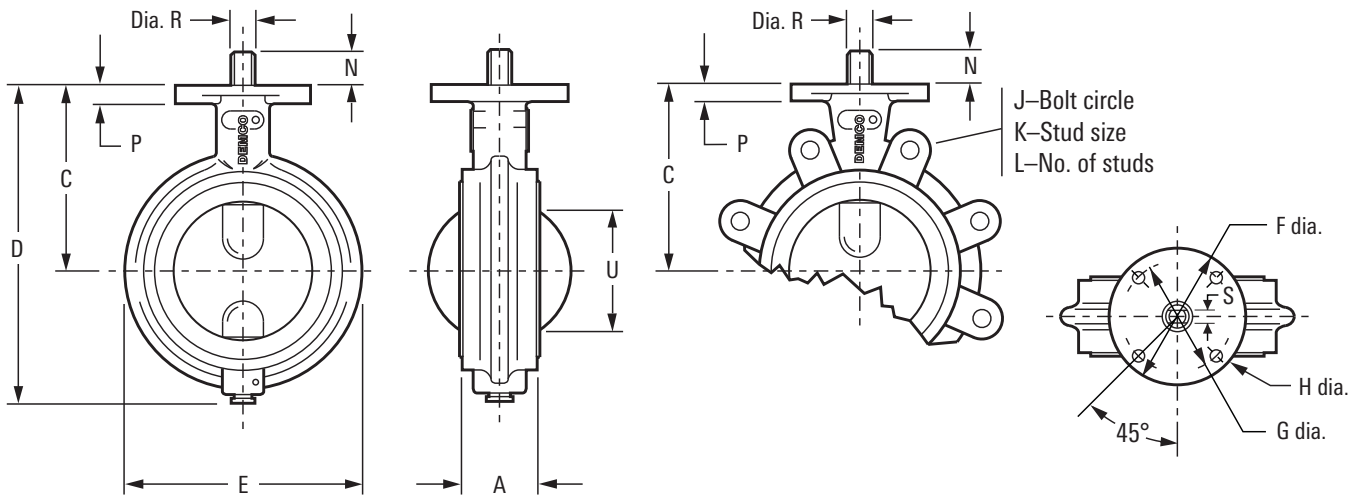

Size, in	A	C	D	E	F	G	H	J	K	L	N	P	R	S	U
2	1.74	3.94	6.75	4.12	4.00	3.25	0.408	4.27	3/8	4	1.00	0.44	0.625	0.375	1.467
2½	1.86	4.44	7.50	4.88	4.00	3.25	0.408	5.31	3/8	4	1.00	0.44	0.625	0.375	2.144
3	1.86	4.88	8.19	5.38	4.00	3.25	0.408	4.91	3/8	6	1.00	0.44	0.625	0.375	2.743
4	2.11	6.00	9.88	6.88	4.00	3.25	0.408	7.03	1/2	6	1.00	0.44	0.625	0.375	3.601
5	2.24	6.00	10.38	7.75	4.00	3.25	0.408	7.56	1/2	6	1.25	0.44	0.838	0.500	4.582
6	2.24	6.50	11.50	8.75	4.00	3.25	0.408	9.16	1/2	8	1.25	0.44	0.838	0.500	5.624
8	2.54	8.06	14.19	11.00	6.00	5.00	0.533	11.72	5/8	8	1.38	0.56	0.838	0.500	7.428
10	2.74	9.97	17.41	13.38	6.00	5.00	0.533	13.72	5/8	8	1.38	0.56	0.963	0.625	9.382
12	3.24	10.91	20.41	16.12	6.00	5.00	0.533	16.62	1/2	12	1.38	0.56	1.338	0.750	11.35
Size, mm															
50	44	100	171	105	102	83	10.36	108	10	4	25	11.2	15.88	9.53	37
65	47	113	191	124	102	83	10.36	135	10	4	25	11.2	15.88	9.53	54
80	47	124	208	137	102	83	10.36	125	10	6	25	11.2	15.88	9.53	70
100	54	152	251	175	102	83	10.36	179	15	6	25	11.2	15.88	9.53	91
125	57	152	264	197	102	83	10.36	192	15	6	32	11.2	21.29	12.70	116
150	57	165	292	222	102	83	10.36	233	15	8	32	11.2	21.29	12.70	142.8
200	65	205	360	279	152	127	13.54	298	16	8	35	14.2	21.29	12.70	189
250	70	253	442	340	152	127	13.54	348	16	8	35	14.2	24.46	15.88	238
300	82	277	518	409	152	127	13.54	422	15	12	35	14.2	33.99	19.05	288

Handles

How to Order

(XXXXX-00X)

XXXXX	00X
Base part number	Trim
	Standard 1
	Corrosion resistant 2

Description, in [mm]	2 to 4 [50 to 100]	5 to 6 [125 to 150]	8 [200]	10 [250]	12 [300]
Ten-position, standard, CR	24227	24228	24229	24230	24231
Two-position, standard	24232	24233	24234	24235	24236
Throttling, standard	24252	24253	24254	24255	24256
Weight, lbm	2.3	2.9	6.5	6.5	6.5

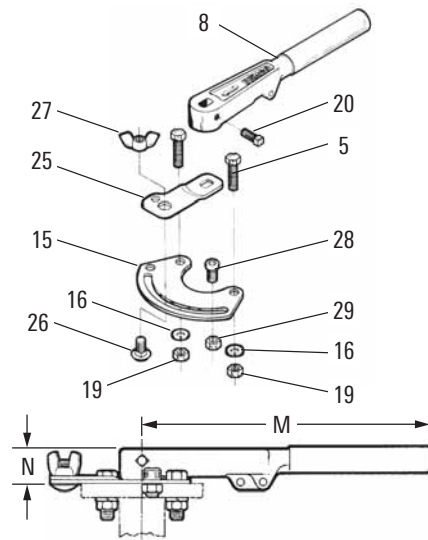
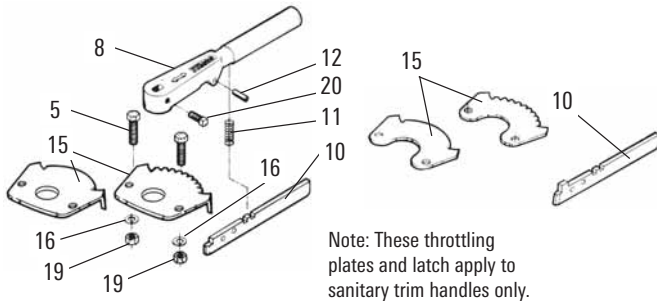

Two- and Ten-Position Locking Handles

Key No.	Description	Material Standard	Corrosion Resistant
5	Screw	Steel	SS
8	Handle	Ductile iron	Ductile iron
10	Latch	Zinc-plated steel	SS
11	Spring	Spring steel	SS
12	Spring pin	Spring steel	SS
15	Throttle plate	Zinc-plated steel	SS
16	Lockwasher	Steel	SS
19	Nut	Steel	SS
20	Set screw	Steel	SS
25 [†]	Throttling tab	Zinc-plated steel	SS
26 [†]	Carriage bolt	Steel	SS
27 [†]	Wing nut	Steel	SS
28 [†]	Screw	Steel	SS
29 [†]	Nut	Steel	SS

[†] For throttling, memory stop handle only.

Infinite Throttling with Memory Stop Handle

Dimension, in [mm]	2 to 4 [50 to 100]	5 to 6 [125 to 150]	8 to 12 [200 to 300]
M	9.50 [241]	11.00 [279]	15.00 [381]
N	0.85 [21.6]	1.07 [27.2]	1.13 [28.7]

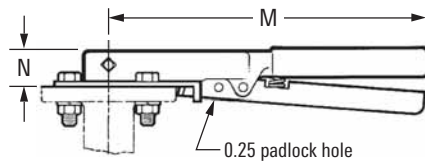

Two- and Ten-Position Locking Handles

Dimension, in [mm]	2 to 4 [50 to 100]	5 to 6 [125 to 150]	8 to 12 [200 to 300]
M	9.50 (241)	11.00 (279)	15.00 (381)
N	0.87 (22.1)	1.07 (27.2)	1.13 (28.7)

Worm Gear Operators

Manual worm gear operators are self locking in all positions. Adjustment screws stop travel at open and closed positions. Position indicator is standard on all models. Gearing is permanently lubricated.

Gray iron weatherproof case and cover enclose a ductile iron gear and hardened steel worm supported by bronze bearings. Standard external coating is green enamel. White epoxy, coal tar epoxy, and inorganic zinc primer are available upon special request.

How to Order

2 to 12 in [50 to 300 mm]

X X X X X	X	X	X	X	X
Base Part Number	Case Material	Gear Material	Actuation	Valve Size, in [mm]	Configuration
↓	Gray iron	Ductile iron	Handwheel	2 to 4 [50 to 100]	Standard
	2	1	3	1	2
			None	5 and 6 [125 and 150]	
			9	5	
				8 [200]	7
			10 [250]	8	
			12 [300]	9	
Description, in [mm]	2-4 [50-500]	5-6 [125-150]	8 [200]	10 [250]	12 [300]
Operator base number	22622	22622	22623	22623	22623
Additional information					
Weight, lbm [kg] with handwheel	7.8 [3.5]	7.8 [3.5]	17.2 [7.8]	17.2 [7.8]	18.6 [8.4]

14 to 36 in [350 to 900 mm]

X X X X X	X					
Base part number	Gear operator assembly part number					
↓	Gear operator less actuation					
	09					
	Gear operator with handwheel					
	03					
Description, in [mm]	14 [350]	16 [400]	18 to 20 [450 to 500]	24 [600]	30 [750]	36 [900]
Operator base number	2060229	2060230	2060231	2060232	2060332	2060334
Additional information						
Weight, lbm [kg] (with handwheel)	19.0 [8.6]	22.0 [10.0]	33.0 [15.0]	43.0 [19.5]	107.0 [48.5]	137.0 [62.1]

Valve Size, in [mm]	Gear Ratio	Turns/90° Rotation	Maximum Input Torque, ft.lbf
2-6 [50-150]	30:1	7½	46
8-12 [200-300]	48:1	12	65
14-16 [350-400]	48:1	12	65
18-20 [450-500]	57:1	14¼	98
24 [600]	60:1	15	164
30 [750]	316:1	79	104
36 [900]	240:1	60	174

(Example: 6 in [150 mm] with handwheel—22622-21352)

Worm Gear Operators

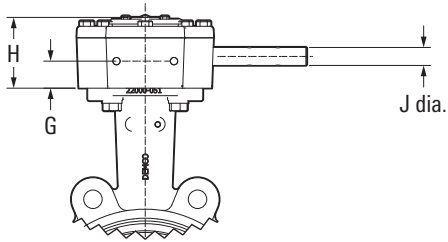
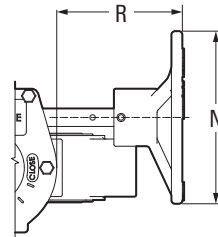
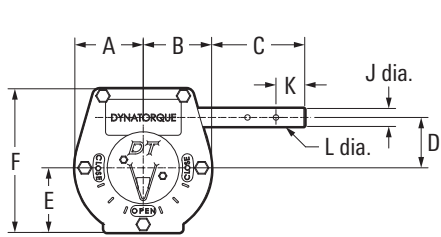

2- to 24-in [50- to 600-mm] valves.

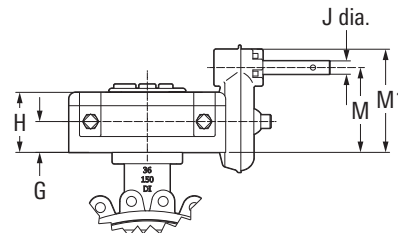
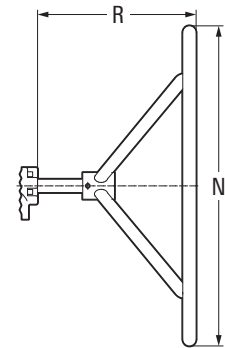
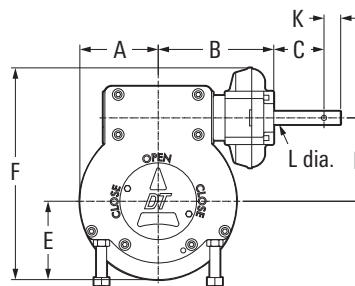

30- to 36-in [750- to 900-mm] valves.

Dimensional Data

Size, in	A	B	C	D	E	F	G	H	J	K	L	M	M1	N	R
2-6	2.38	2.38	3.23	1.75	2.25	5	1.1	2.62	0.625	1	0.19	-	-	6	4.23
8-10	3	3	3.24	2.51	2.98	6.71	1.37	2.92	0.625	1	0.19	-	-	6	4.24
12	3	3	3.24	2.51	2.98	6.71	1.37	2.92	0.625	1	0.19	-	-	10	4.86
14	3	3	4.98	2.51	2.98	6.71	1.37	2.92	0.625	1.25	0.19	-	-	12	8.98
16	3	3	5.73	2.51	2.98	6.71	1.37	2.92	0.625	1.25	0.25	-	-	18	10.73
18-20	3.2	3.2	7.05	3	3.2	7.84	1.5	3.18	1	1.25	0.25	-	-	18	12.05
24	3.56	3.56	7.94	3.63	3.25	8.38	1.63	3.54	1	1.25	0.38	-	-	24	15.06
30	5.68	9.92	4.09	4.3	4.44	14.24	2	4.2	1	1.25	0.39	4.94	6.51	18	9.09
36	6.49	9.6	4.09	7.3	6.5	17.41	2.31	5.12	1	1.25	0.39	5.19	6.57	24	11.21

Size, mm

50-150	60	60	82	44	57	127	28	67	16	25	5	-	-	152	107
200-250	76	76	82	64	76	170	35	74	16	25	5	-	-	152	108
300	76	76	82	64	76	170	35	74	16	25	5	-	-	254	123
350	76	76	126	64	76	170	35	74	16	32	5	-	-	305	228
400	76	76	146	64	76	170	35	74	16	32	6	-	-	457	273
450-500	81	81	179	76	81	199	38	81	25	32	6	-	-	457	306
600	90	90	202	92	83	213	41	90	25	32	10	-	-	610	383
750	144	252	104	109	113	362	51	107	25	32	10	125	165	457	231
900	165	244	104	185	165	442	59	130	25	32	10	132	167	610	285

¹DT-1 gear operator dimensions became standard gear operator mid-year 2000 (for old style DT-3, consult Cameron).

General Technical Information

Pressure rating

Three drop-tight pressure ratings are offered for butterfly-style DEMCO valves. Normally, 200-psi shutoff is used in butterfly applications. However, 285-psi shutoff is optionally available for higher pressure applications. For smaller actuator sizing, 50-psi valves offer reduced torque.

For reduced torque, throttling valves—which do not provide drop-tight closure—are available.

Vacuum rating

Butterfly-style DEMCO valves will seal against 10 um of vacuum (29.9 in-Hg). For reduced torque and extended seat life, 50-psi discs are recommended for the dry service conditions found in many vacuum applications.

End-of-line service

Lug body valves can be used in end-of-line service, with downstream piping removed. Only weld neck or socket flanges can be used for this service. Since upstream pressure is excluded between the flange and the seat face by the exclusive DEMCO valve flange seal, there is no effective force to slide the seat downstream. Lug butterfly-style DEMCO valves are recommended for liquid service up to 200 psi with downstream piping removed.

Lug body valves are recommended for the isolation of pumps, control devices, or other system components that may need to be removed for repair or replacement.

Lug valves also are suitable for installation at points from which piping expansions may proceed. Such valves normally are blanked with blind flanges to protect the exposed seats until new piping is attached.

Marking

Each valve is positively identified by marking and tagging per MSS SP-25.

Actuation

Positive latch handles, worm gear operators, and automatic actuators are available and interchangeable on the DEMCO valve.

The DEMCO valve's top flange is dimensionally compatible with other butterfly valves. With the optional "utility top" stem, the DEMCO valve interchanges directly with other valves, enabling valve replacement without the need for new actuation.

Installation and maintenance

Butterfly-style DEMCO valves are bidirectional, with identical flow way from either face. To install, simply close the valve, insert between flanges, and make up with studs or cap screws. No regular maintenance or lubrication is required. Disassembly for inspection or replacement of parts is simple.

Open the valve, remove handle or actuator, remove tangential pins, pull out the stems, and push the disc and seat out of the body. Reassemble in reverse order, with a small amount of general-purpose nonhydrocarbon-based lubricant on the outside of stems, seat, and disc flats.

Steel or cast iron flanges of either raised- or flat-faced type are suitable for use with butterfly-style DEMCO valves. Plastic flanges are subject to damage at installation by overtightening the bolting and may deflect or cup, resulting in flange leaks. Refer proposed plastic flange installations to Cameron for review and recommendation.

Throttling discs with no seat interference do not provide a stem seal. Stem O-rings are provided for this application. Flange gaskets assist the O-rings in 2- to 12-in [50- to 300-mm] valves and must be used only with throttling discs.

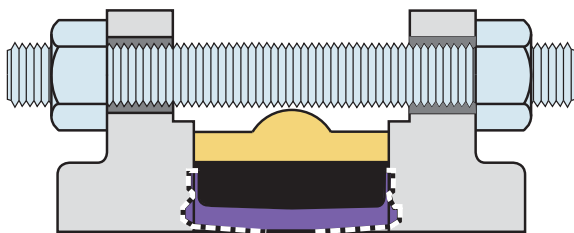

Wafer valve connection.

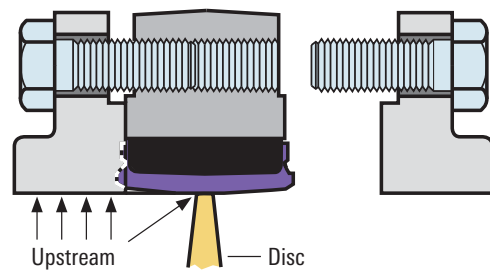

Lug valve connection with downstream flange removed.

Torque Data

The torque required to operate a given butterfly valve is determined by two factors: friction of the disc and the seat. The interference and dynamic forces of flow through the valve tend to open or close the valve. The actuator torque output must meet or exceed the maximum torque requirement of the valve. Dry service will increase opening torque significantly. Consult Cameron for dry service torque requirements.

The disc of a butterfly valve, in partially opened condition, is subject to lift forces from passage of fluid over its surfaces.

This effect is analogous to an airplane wing and results in an unbalanced turning force on the disc. The dynamic torque is proportional to the pressure drop through the valve and may become significant in some applications.

Dynamic torque typically is at a maximum when the disk opening is about 70°. Under high differential pressure conditions, such torque may exceed the design strength of stems, connections, or actuators.

Butterfly Valve Torques (Except Series NEI-T)[†]—Normal Wet Opening, in.lbf

Valve Size, in [mm]	2 [50]	2½ [65]	3 [80]	4 [100]	5 [125]	6 [150]	8 [200]	10 [250]	12 [300]	14 [350]	16 [400]	18 [450]	20 [500]	24 [600]	30 [750]	36 [900]
285-psi shutoff	225	326	510	765	1,190	1,530	2,550	4,125	7,000	15,000	20,500	38,400	45,000	65,000	82,000	90,000
200-psi shutoff	132	192	300	450	700	900	1,500	2,650	4,500	—	—	—	—	—	—	—
150-psi shutoff	—	—	—	—	—	—	—	—	—	7,740	10,280	12,600	15,600	30,000	50,000	67,500
50-psi shutoff	108	108	192	264	450	550	1,000	1,800	3,000	4,500	6,500	8,400	10,800	20,000	30,000	50,000
Throttling [†]	72	72	90	108	144	180	350	700	1,160	1,660	2,800	3,400	5,000	8,400	—	—

[†]When line velocity exceeds 15 ft/s, dynamic torque exceeds opening torque.

Standard Material Data

Bodies

Description	NE-C	NF-C 14–24 in	NF-C 30 and 36 in	NE-I	NE-D
See page 10 for assembly part number					
Ductile iron	A395 (60-40-18) [†]	Wafer/Lug	Wafer/Lug	Wafer/lug	Wafer
Aluminum	B148 (954)	●		●	●
Bronze	B148 (952)		C/F	Wafer/lug	
Steel	A216 (WCB) [†]		Lug	Wafer/lug	
SS	A351 (CF8M)			Wafer/lug	

Discs

Ductile iron or nickel plated	A536 (65-45-12)	●	●	●	●
Bronze	B148 (955)		●	●	
316 SS	A743 (CF8M)	●	●	●	●

Stems

416 SS	QQ-S-764-B	●	●	●	●
316 SS	AMS 5648 B	●	●	●	●
17-4 PH SS	AMS 5643	●	●	●	●

[†]Conforms to USCG Marine requirements, as outlined in 46 CFR, part 56. Consult Cameron for special material requirements.

Seats vary. See pages 10, 11, and 12 for seat material description and part number scheme for available options for different valve series.

Buna-N is a general-purpose elastomer compounded for maximum hydrocarbon or petroleum resistance. Temperature rating is 0 to 180 degF [–18 to 82 degC], the same as nitrile, Hycar[®] and NBR.

General service EPDM is recommended for water service. Resistance to saturated steam up to 275 degF [135 degC] is superior. EPDM is suitable in alkaline solutions. EPDM is not suitable for oil or hydrocarbons. Peroxide-cured version is rated to 20 to 275 degF [–6 to 135 degC].

FKM is superior at elevated temperatures and in harsh chemical environments. FKM is not suitable for hot water or steam. Temperature rating is 20 to 300 degF [–6 to 149 degC], the same as fluoroelastomer.

Natural rubber generally is superior to other elastomers in abrasion resistance and is recommended for dry material handling. Use in oils and solvents is not recommended. Temperature rating is from –30 to 150 degF [–34 to 65 degC].

Other seat elastomers are available for special applications. Consult Cameron.

Fire Test

DEMCO butterfly valves with the resilient seat design have been fire tested and qualified to meet the stringent requirements of API Spec 607 4th Edition. This valve design provides fire-test capabilities regardless of flow direction.

Sizes Qualified	2 to 6 in	8 to 36 in
Body style	Lug	Wafer and lug
Body material	Ductile iron	Ductile iron
Seat material	FKM	FKM
Working pressure	285 psi	200 and 285 psi

ZPEX coating system

The ZPEX coating is designed specifically for severe service environments. ZPEX system is ideal for oil and gas, salt water, water treatment, chemical processing, and other extreme applications. Unlike single-component coatings, the ZPEX system has been designed as a system of interdependent thin-film coatings working in concert to provide the ultimate protection for extreme environments.

The ZPEX system begins with an electrodeposited epoxy primer (e-coat), wherein the part is immersed in a series of tanks consisting of cleaning, pretreatment, and epoxy coating. This primer process creates a chemical-resistant base coat that forms an electromolecular bond with the substrate as well as provides corrosion protection to 100% of the part, even in hard-to-reach recesses and threads.

To complete the ZPEX system, a fluoropolymer topcoat is applied over the e-coat primer. The superior bond created in our patented crosslinking of the epoxy and fluoropolymer coatings prevents the ZPEX system from chipping or peeling and prevents corrosion from creeping under the coating if ever compromised.

The system can replace stainless steel in most corrosive environments, including salt water and hydrogen sulfide. The ZPEX system has also outlasted stainless steel 7x over at a fraction of the cost. The lead time is approximately 1 week.

ZPEX system advantages

- Lower energy consumption while increasing flow rates in pump applications
- Prevention of thread galling
- Reduced downtime
- High abrasion resistance
- Thin film for application on ring grooves, Victaulic® connections, threaded connections, machined surfaces, and recessed areas
- < 4,000-h ASTM B117 salt spray
- Excellent performance in HPHT autoclave testing
- 500-degF [260-degC] maximum operating temperature
- 2.0- to 2.8-mil dry film thickness
- Low coefficient of friction (.016)



Fire test per API Spec 607 4th Edition.

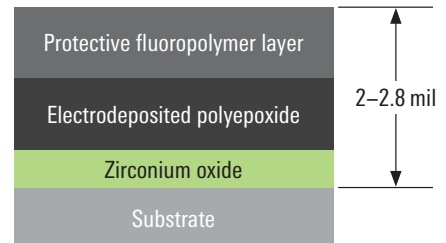

ZPEX layer composition.

Butterfly-Style DEMCO Valves



cameron.slb.com/valves

*Mark of Schlumberger
Other company, product, and service names
are the properties of their respective owners.
Copyright © 2018 Schlumberger. All rights reserved. 17-VL-294948

